

# Submersible drainage pump XJ 900



## Specification

Electric submersible pump with double outer casing.  
 Maximum submergence: 80 m. Protection class IP68.  
 Max temperature of pumped medium at max power input and continuous duty 40 °C.  
 Max medium density 1100 kg/m<sup>3</sup>. pH of the pumped medium 5-8.  
 Strainer hole: 8 x 34 mm. Max number of starts 15/hr.

**XJ 900 ND** High flow, 3-phase  
**XJ 900 HD** High head, 3-phase

## IE3 electric motor

3-phase squirrel-cage induction motor, 50 Hz.  
 Service factor 1.1. Class F insulation.  
 Motor rating P<sub>2</sub>: 90 kW. 2 pol. Speed: 2970 rpm.  
 η: 96.1 (50 %), 96.0 (75 %), 95.6 (100 % load)

Voltage, V	400	500-550	690	1000
Nominal current, A	155	124	90	62

## Motor protection

- Thermal control system with temperature sensors in the motor windings for automatic shut-down in case of overheating
- Seal monitoring system with leakage sensor in the junction box and motor chamber for automatic shut-down if water has entered into the pump
- Leakage sensor in the oil chamber that signals an inspection alert, indicating the presence of water in the oil
- Optional bearing monitoring system with temperature sensors at upper and lower bearing indicating excessive temperature

## Power cable

Standard length 20 m (longer cable on request).  
 Type NSSHOEU: allowed lengths 20-100 m  
 3x50+3x25/E+3x2.5ST  
 3x16+3x16/E+3x2.5ST (1000 V)  
 Control cable: type H07RN-F 10G1.5 sq. mm or 12G1.5 sq. mm

## Shaft seal

Double mechanical seal in oil bath.  
 Primary seal: Silicon carbide on silicon carbide.  
 Secondary seal: Silicon carbide on silicon carbide.

## Bearings

Upper bearing: Single-row cylindrical roller bearing.  
 Lower bearing: Double-row angular contact ball bearing.

## Discharge connections

Flanged connection EN 1092-1 PN40:

- DN100/4" discharge (Standard HD)
- DN150/6" discharge (Standard ND)

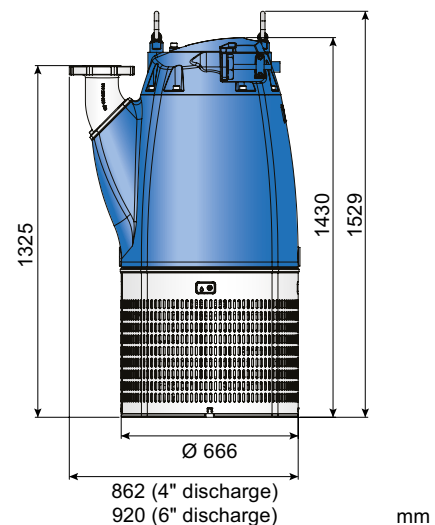
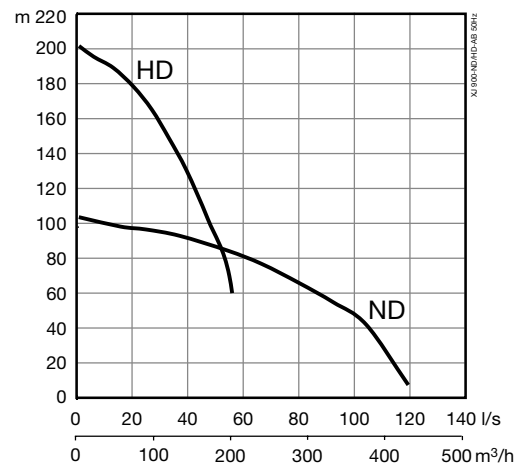

## Weight

1200 kg (without cable)

## Options and accessories

HD/ND conversion kit  
 Bearing temperature sensors  
 Repair kit  
 Hydraulic service kit

ISO9001 certified



P: 03 8805 0500  
 E: sales@toolkwippumps.com  
 A: 8-10 Parkhurst Drive  
 Knoxfield VIC 3180

## Materials

Description	Material	EN	ASTM
Structural castings	Cast iron	EN-GJL-250	ASTM A48 - Class 35
Volute casings	Cast iron	EN-GJL-250	ASTM A48 - Class 35
Outer jacket / Discharge	Ductile iron	EN-GJS-400-18	ASTM A536 60-40-18
Strainer / Handle	Stainless steel	10088:X5CrNi18-10 (1.4301)	AISI 304
Rotor shaft	Stainless steel	10088:X20Cr13 (1.4021)	AISI 420
Impeller / Wear rings / Flow elbows	White cast iron	EN-GJN-HV600(XCr23)	ASTM A 532: Alloy III A
Fasteners	Stainless steel	10088:X5CrNiMo 17122 (1.4401)	AISI 316
Volute coating / O-rings	Nitrile rubber		
Coating	2 component epoxy paint 120 µm		