

# Submersible Drainage Pump J 604

## Specification

Electric submersible pump.  
 Maximum submergence: 20 m. Protection class IP 68.  
 Max temperature of pumped medium at max power input and continuous duty 40 °C.  
 Max medium density 1100 kg/m<sup>3</sup>. pH of the pumped medium 5-8.  
 Strainer hole: 12 x 60 mm. Max number of starts 30/hour.

**J 604 ND** Medium head, 3-phase

**J 604 HD** High head, 3-phase

## Electric Motor

3-phase squirrel-cage induction motor, 50 Hz.  
 Service factor 1.1. Class F insulation.  
 Motor rating P<sub>2</sub>: 56.0 kW. Speed: 1450 rpm.

Voltage, V	230	400	500-550	690	1000
Nominal current, A	184	106	84	61	42

## Starting Method and Motor Protection

D.O.L. start with built-in terminal block.  
 Star-Delta start with built-in terminal block.  
 When used with VFD, pump must be equipped with terminal block.

## Power Cable

20 m type H07RN8-F (standard cable):  
 2-4x16 sq.mm.+H07RN8-F 7x1.5 sq.mm. (400-550 V star-delta start)  
 2-4x10 sq.mm.+H07RN8-F 7x1.5 sq.mm. (690 V star-delta start)  
 4x25 sq.mm.+H07RN8-F 7x1.5 sq.mm. (690 V DOL-start)

20 m type H07RN8-F (standard cable):  
 2-4x35 sq.mm.+H07RN8-F 7x1.5 sq.mm. (230 V star-delta start)  
 4x35 sq.mm.+H07RN8-F 7x1.5 sq.mm. (400-550 V DOL-start)

20 m type NSSHÖU.../3E (heavy duty cable):  
 3x10+3x10/3E+3x2.5 (3 control cables included) (1000 V DOL-start)  
 3x16+3x16/3E+3x2.5 (3 control cables included) (690 V DOL-start)  
 3x25+3x16/3E+3x2.5 (3 control cables included) (400-550 V DOL-start)

## Motor Protection

Built-in thermal switches in the stator winding (140°C, ±5).  
 DI leakage sensor in the junction box, DI leakage sensor in the oil chamber, thermal sensors at upper (120°C) and lower (90°C) bearing connected to a separate starter and control unit.

## Shaft Seal

Double mechanical seal in oil bath.  
 Primary seal: Silicon carbide on silicon carbide.  
 Secondary seal: Carbon on stainless steel.

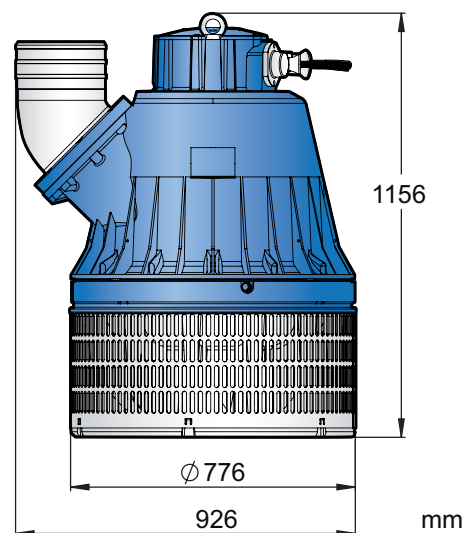
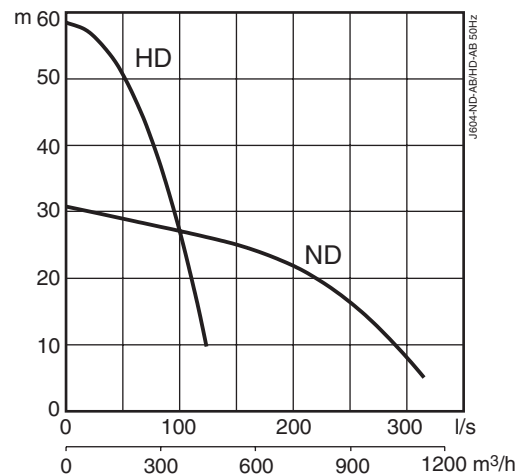

## Bearings

Upper bearing: Single-row deep groove ball bearing.  
 Lower bearing: Double angular contact ball bearing.

## Discharge Connections

6" (standard HD), 8", 10" (standard ND) hose connections.  
 6", 8" G/B.S.P. threaded connections.

## Weight

525 kg (without cable)

## Options and Accessories

Zinc anodes. Surface protection coating.  
 Wear plate in polyurethane. Series connection (HD).  
 Starter and control units. Automatic level control unit.  
 Floatation system. Repair kit.  
 Discharge connection accessories and hose.

## Materials

Description	Material	EN	ASTM
Casing and castings	Aluminium	EN 1706:AC-43100	ASTM A1Si10mg
Strainer and fasteners	Stainless steel	10088:X5CrNi18-10 (1.4301)	AISI 304
Shaft	Stainless steel	10088:X20Cr13 (1.4021)	AISI 420
Impeller	White cast iron	EN-GJN-HV600(XCr23)	ASTM A 532: Alloy III A
Wear parts / O-rings	Nitrile rubber		