

# Submersible sludge pump XJS 110



## Specification

Electric submersible pump. Maximum submergence: 20 m.  
Protection class IP 68. Max temperature of pumped medium at max power input and continuous duty 40 °C.  
Max medium density 1100 kg/m<sup>3</sup>. pH of the pumped medium 5-8.  
Free passage: 48 x 60 mm. Max number of starts 30/hour.  
Min. impeller diameter for duty with low water level or intermittent dry running. Max impeller diameter requires half motor or more submersed for continuous duty. (Pump can operate lying down.)

**XJS 110 D - 170** 3-phase

**XJS 110 D - 170 AT\*** 3-phase

**XJS 110 D - 195** 3-phase

**XJS 110 D - 195 AT\*** 3-phase

\*AquaTronic: Built-in electronic pump control.

## Electric motor

3-phase squirrel-cage induction motor, 50 Hz.  
Service factor 1.1. Class F insulation.  
Motor rating P<sub>2</sub>: 11.8 kW. 2 pol. Speed: 2920 rpm.  
η: 89.8 (50 %), 90.9 (75 %), 90.8 (100 % load)

Voltage, V	230	400	500-550	690	1000
Nominal current, A	37.4	21.5	17.2	12.5	8.6

## Starting method and motor protection

**XJS 110 AT:** Direct on line start (DOL 500-550 V) with built in AquaTronic unit, which automatically adjusts phase order by dual contactors, ensuring correct motor rotation.  
Soft start (400 V) is built in with the AquaTronic unit, where three thyristors reduces start current to three times the nominal current. Here two relays ensure correct motor rotation. The AquaTronic unit monitors motor temperature, by use of NTC thermistors built into stator windings, and stops the motor at high temperature. It will also stop the motor at high amperage or if a phase is missing.

**XJS 110:** Direct on line start with built in contactor. Pumps to be used with VFD or 1000 V must have terminal block instead of contactor. Thermal switches (140 °C, ±5) built into the stator windings are connected to the contactor and stop the pump at high temperature.

## Power cable

20 m type H07RN8-F (standard cable):

4 x 6 sq.mm. (230 V)

4 x 4 sq.mm. (400 V, 500-550 V)

4 x 2.5 sq.mm. (690 V)

20 m type NSSHÖU.../3E (heavy duty cable):

3x6+3x6/3E+3x1.5 (3 control cables included) (230-400 V terminal block)

3x2.5+3x2.5/3E+3x1.5 (3 control cables included) (500-1000 V terminal block)

3x6+3x6/3E+3x1.5 (230-400 V)

3x2.5+3x2.5/3E (500-550 V, 690 V)

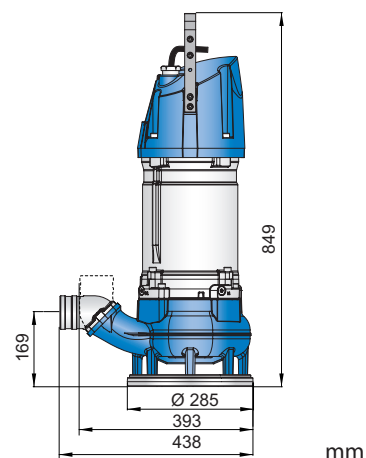
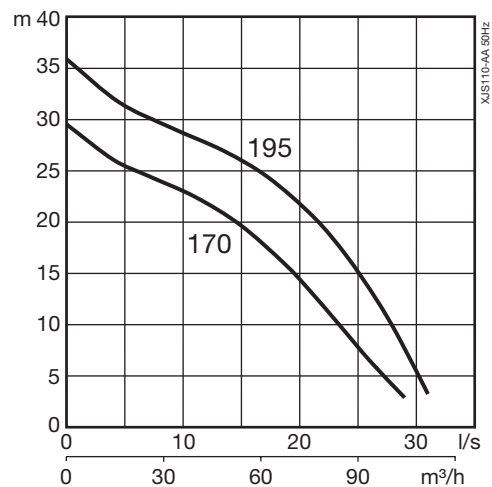

## Shaft seal

Double mechanical seal in oil bath.  
Primary seal: Silicon carbide on silicon carbide.  
Secondary seal: Silicon carbide on carbon.

## Bearings

Upper bearing: Single-row deep groove ball bearing.  
Lower bearing: Double angular contact ball bearing.

## Discharge connections

2 ½", 3" (standard), 4" hose connections.  
2 ½", 3", 4" G/B.S.P. threaded connections.

## Weight

80 kg (without cable)

## Options and accessories

AquaPlug. AquaTronic control panel.  
Level sensor. Service data kit. Zinc anodes.  
Surface protection coating. Floatation system.  
Discharge connection accessories and hose.



P: 03 8805 0500  
E: sales@toolkwippumps.com  
A: 8-10 Parkhurst Drive  
Knoxfield VIC 3180

## Pump control

Features	XJS 110	XJS 110 AT				Service Data Kit Read out
		AT	AT + Level Sensor	AT + AquaPlug / AquaTronic Control Panel	AT + AquaPlug / AquaTronic Control Panel + Level Sensor	
Run mode	X	X	X	X	X	
Integrated start equipment	X	X	X	X	X	
Automatic direction of rotation		X	X	X	X	
Motor protection high temp	X	X	X	X	X	X
Motor protection high amp		X	X	X	X	X
Protection against missing phase		X	X	X	X	X
Level control			X		X	
Dry run protection			X		X	
Automatic restarting			X		X	
Stop mode				X	X	
E-mode (Automatic stop/run)			X		X	
Indication of water in oil				X	X	X
Indication of low motor insulation				X	X	X
Indication of high or low voltage				XX	XX	X
Indication of high temperature				XX	XX	X
Indication of high amp				XX	XX	X
Indication of phase unbalance				XX	XX	X
USB cable connection		X	X	X	X	X
Crash log (10 latest)						X
Documentation (spare part list, workshop manual)						X

XX = Fault indication when pump is automatically stopped to protect the motor.

## Materials

Description	Material	EN	ASTM
Motor housing	Aluminium	EN 1706:AC-43100	ASTM A1Si10mg
Handle	Stainless steel	10088:X5CrNi18-10 (1.4301)	AISI 304
Rotor shaft	Stainless steel	10088:X20Cr13 (1.4021)	AISI 420
Volute / Impeller	Nodular cast iron	1563:ENGJS-HB150	ASTM A 536-80:60-40-18
Fasteners	Stainless steel	10088:X5CrNiMo 17122 (1.4401)	AISI 316
O-rings	Nitrile rubber		
Coating	2 component epoxy paint 120 µm		