

FLO-KWIP

SDC 12-30 MK II DATA SHEET

HEAVY DUTY 12V DC SUBMERSIBLE CONTRACTOR PUMP



APPLICATIONS

These D.C. electric submersible pumps at 12V are suitable for the lifting of dirty water. Driven by normal batteries they are particularly used for the lifting of water from road drain wells, basements and from sites where the electric current is not available. For battery power applications. Rugged stainless steel / cast iron construction. High Performance / Low weight: 240LPM/ 11kg plus cables.

SPECIFICATIONS

Max Temp:	40°C
pH Range:	6-10
Max Immersion depth:	5m
Liquid Density:	1,0 kg/dm ³
Discharge:	40mm, 1 1/2" FBSP
Min immersion depth for continuous service:	300mm
Free passage:	
Pump:	13mm
Strainer:	8mm
Max number starts/hour:	20
Inlet with strainer:	free passage 8mm

TECHNICAL SPECIFICATIONS

Model:	SDC12-30
P1 kW:	0,40
P2 kW:	0.30
Voltage:	12VDC
Current:	34A
Cable:	10m
Weight:	11kg + cable

MATERIALS

Cover:

Cast iron EN GJL 200 (UNI EN 1561)

Pump housing:

Cast iron EN GJL 200 (UNI EN 1561)

Supporting foot:

Cast iron EN GJL 200 (UNI EN 1561)

Impeller:

Cast iron EN GJL 200 (UNI EN 1561)

Mechanical seal:

Silicon Carbide/Silicon Carbide (SiC/SiC)

Motor housing:

Stainless steel AISI 304

Motor shaft:

Stainless steel AISI 416

Bolts and nuts:

Stainless steel Grde A2

Cable:

10 meters type H07RN-F 1G16mm| and battery clamps

MOTOR

12VDC / 0.3kW

The electric motor is asynchronous with squirrelcage rotor in dry chamber

Class of insulation F

Protection degree IP68

Main voltage values and relative tolerance in relation to the rated voltage value:

12V D.C. +10% ÷ -5%

SEMI-OPEN IMPELLER

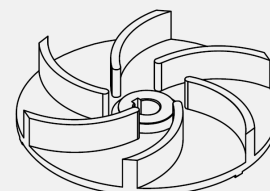

PERFORMANCE CURVE

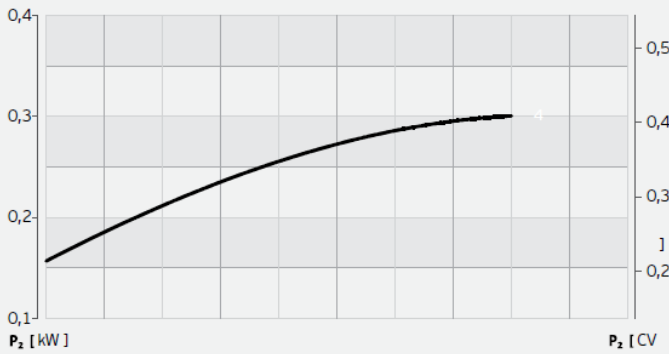
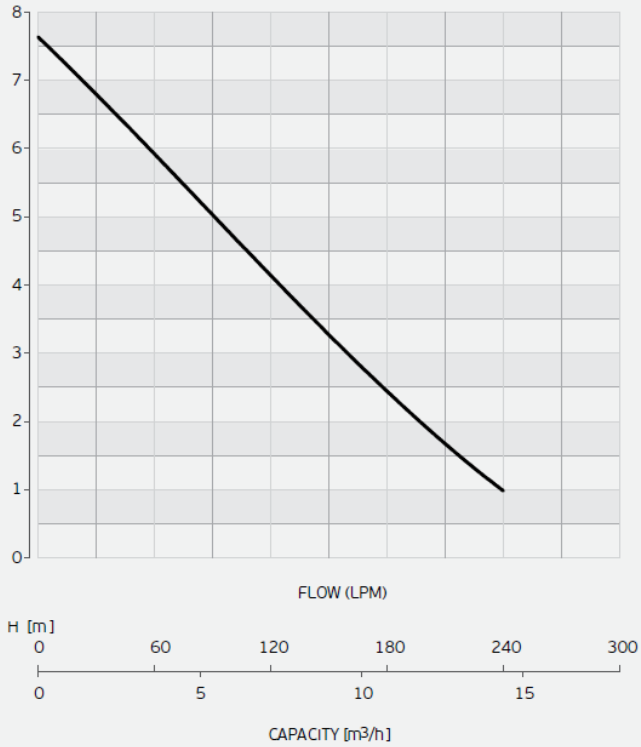

Performance tolerance in according to UNI/ISO 9906 Grade 2

INSTALLATION DIMENSIONS

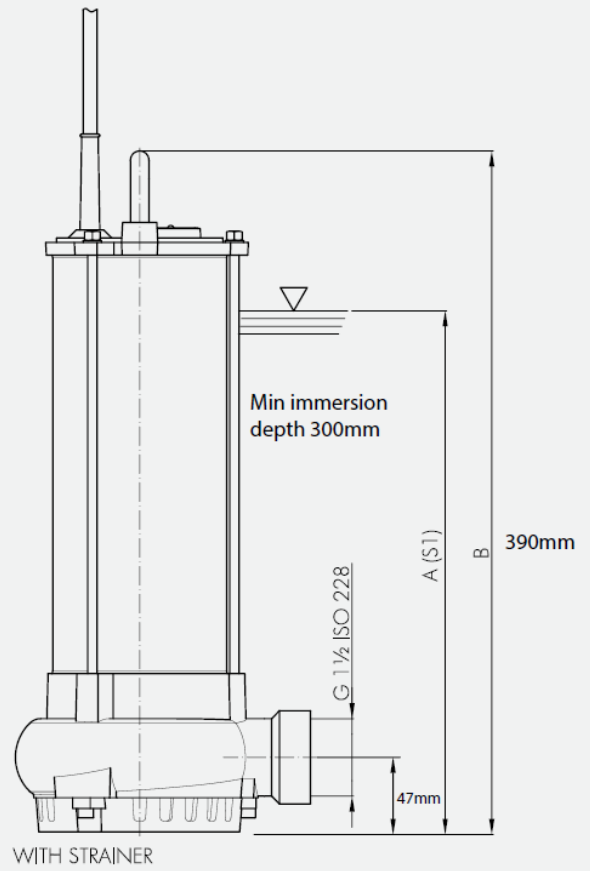

	A	B
SDC12-30	300	390

